

Nomad

SERVICE BULLETIN

REDESIGNED CABLE CLAMPS FOR AUTOPILOT RUDDER SERVO BRIDLE CABLE (MODIFICATION N555)

1. PLANNING INFORMATION

A. Effectivity

(1) Aircraft Affected

- (a) All Nomad N22-Series Aircraft fitted with Option G101 autopilot systems whose log books do not already record the embodiment of Mod N555 or compliance with Service Bulletin NMD-27-26 Revision 1.
- (b) All Nomad N24-Series Aircraft fitted with Option G101-24 autopilot systems whose log books do not already record the embodiment of Mod N555 or compliance with Service Bulletin NMD-27-26 Revision 1.

Pre-certification implementation of the intent of this service bulletin is recorded in the airframe log book as Mod N555.

(2) Spares Affected

Nil.

B. Reason

To improve the fatigue life of the autopilot bridle cable in the rudder autopilot control system.

C. Description

The cable clamp assemblies which secure the autopilot bridle cable of the rudder control system are replaced by two more efficient type clamps.

D. Compliance

Within 200 hours time in service after receipt of Kit PN NMD-27-26-1.

E. Approval

The modification detailed herein has been approved pursuant to Air Navigation Regulation 40 and conforms with type certification

F. Manpower

2 Manhours.

Page No	1	2	3	4	5
Rev No	1	1	1	1	1

Nomad

SERVICE BULLETIN

G. **Material – Price and Availability**

The Kit required to incorporate the modification detailed in this Service Bulletin is available free of Charge as Kit PN NMD–27–26–1 from the operator's local distributor. Distributors are to place a "No Charge" purchase order on GAF through the normal procurement procedure. Purchase orders are to quote the Aircraft Serial No. and Service Bulletin No. NMD–27–26 Revision 1. This kit will be available ex–factory from October, 1982.

H. **Tooling – Price and Availability**

None required.

I. **Weight and Balance**

Negligible effect.

J. **References**

Maintenance Manual

Maintenance Manual and Illustrated Parts Catalogue sections of the following Customer Option Supplements G101, G101–24.

K. **Publications Affected**

Maintenance Manual and Illustrated Parts Catalogue sections of the following Customer Option Supplements G101, G101–24.

2. **ACCOMPLISHMENT INSTRUCTIONS**

WARNING

DO NOT OPERATE FLIGHT CONTROLS WHILST PERSONNEL ARE WORKING IN THE AREA. SERIOUS INJURY COULD RESULT.

- A. Replace the bridle cable clamp assemblies 1/N–45–1315 (Ref Customer Option G101 or G101–24 Supplement I.P.C. Section, Figure 1 Sheet 2, item (–15) (N22) and item (–14) (N24).
- (1) Select the BATTERY switch to OFF and trip the autopilot circuit breaker identified AFCS located on the overhead console.
 - (2) Remove the access panel at Sta 445 (N22) or Sta 490 (N24) in the fuselage skin to gain access to the bridle cable clamp assemblies.
 - (3) Set the rudder to the streamline position using the rigging bar PN 1/N–88–80 and rigging pins PN 1/N–88–60 (Ref MM Chap 27–20–00, Fig 201).
 - (4) Gain access to the servo bridle cable turnbuckle through the aperture in the fuselage skin, remove the locking clips from the turnbuckle body and release the tension on the rudder bridle cable by unscrewing the turnbuckle body.
 - (5) Remove and discard the clamp assemblies from the LH and RH rudder servo bridle cables.

Nomad

SERVICE BULLETIN



ALWAYS TENSION THE RUDDER PRIMARY CABLES WITH THE BRIDLE CABLES SLACKENED OR DISCONNECTED.

- (6) Check the tension of the rudder primary cables using a suitable tensiometer and adjust the tensions as necessary (Ref MM Chap 27-20-00).
- (7) Disconnect the rudder LH turn bridle cable PN 3/N-45-1317 from the turnbuckle and discard.
- (8) Install the turnbuckle eye-end PN MS21254-2LS into the end of the turnbuckle from which the cable in step (7) was removed.
- (9) Loosely assemble the two clamps PN 1/N-45-1625 and 1/N-45-1626 onto the rudder LH turn primary cable and the eye-end of the turnbuckle using bolts PN AN3-6A, washers PN AN960PD10L and self-locking nuts PN MS21042-L3. Install the eye-end fitting retaining bolt PN AN3-6, washer P/N AN960PD10, castellated nut PN AN320-3 and split cotter pin PN MS24665-153.
- (10) Loosely assemble the two clamps PN 047-3536-01 to the rudder RH turn primary cable and the rudder RH turn bridle cable using bolts PN AN3-6A, washers PN AN960PD10L and self-locking nuts PN MS21042-L3.
- (11) Stretch the servo cables until taut without turning the rudder servo cable capstan. Ensure that each bridle cable is wrapped around the capstan approximately 2 (two) turns and seated correctly in the servo capstan grooves and that the cable clamps PN 1/N-45-1625 and 1/N-45-1626 are positioned on the rudder LH turn primary cable so that they will have 0.5 inch clearance from pulley bracket PN 1/N-12-264 (at Sta 451.35 (N22) or Sta 496.35 (N24)) when full right rudder is applied. Torque tighten the cable clamp nuts to between 20 and 25 lb in.
- (12) Tighten the eye-end retaining bolt and castellated nut ensuring that the eye-end can rotate freely within the clamp before installing the split cotter pin.
- (13) Using the servo bridle cable turnbuckle, and a tensiometer, tension the cables to between 30 and 40 lbs. Check that the turnbuckle is in safety and then refit the turnbuckle locking clips.
- (14) After tensioning the rudder servo bridle cables, re-check that the tension of the rudder primary cables is still within tolerance. (Ref MM Chap 27-20-00).
- (15) Remove rigging pins and rigging bar PN 1/N-88-60 and PN 1/N-88-80 installed in Para 2.A.(3).
- (16) Operate the rudder control through its full range and ensure no restrictions to movement exist. With rudder full right check that at least 0.5 inch clearance exists between the cable clamps PN 1/N-45-1625 and 1/N-45-1626 and the pulley bracket PN 1/N-12-264 at Sta 451.35 (N22) or Sta 496.35 (N24).
- (17) Refit the access panel removed at Para 2.A.(2).

Nomad

SERVICE BULLETIN

WARNING

AFTER ALL MAINTENANCE ACTIVITIES INVOLVING FLYING CONTROLS OR WHENEVER FLYING CONTROL SERVICING AND ACCESS PANELS ARE REMOVED ENSURE THAT THE AREAS CONCERNED ARE CLEAN AND FREE FROM FOREIGN OBJECTS.

- B. Functionally test the autopilot system for correct operation
(Ref Customer Option G101 or G101-24 Supplements and Collins Radio Co handbooks).

3. MATERIALS INFORMATION

A. Parts Required per Aircraft

- (1) One Kit PN NMD-27-26-1 is required per Aircraft.
- (2) Each Kit PN NMD-27-26-1 comprises the following items

Part No	Qty	Description
047-3536-01	2	Clamp, Cable (King)
1/N-45-1625	1	Clamp, Bridle Cable
1/N-45-1626	1	Clamp, Bridle Cable
MS21254-2LS	1	Eye-end, Turnbuckle
AN3-6A	6	Bolt
AN960PD10L	6	Washer
MS21042-L3	6	Nut, Self-Locking
AN3-6	1	Bolt, Drilled Shank
AN320-3	1	Nut, Castellated
AN960PD10	1	Washer
MS24665-153	1	Pin, Cotter, Split

B. Parts Modified and Re-identified by Operator

None.

C. Parts Required to Modify Spares

None.

Nomad

SERVICE BULLETIN

D. **Removed Parts**

Part No	Qty	Description	Instruction/Disposition
1/N-45-1315	2	Clamp Assembly	Scrap
3/N-45-1317	1	Cable Assembly	Scrap

E. **Special Tools and Equipment**

None.

F. **Recording Action**

Record compliance with Service Bulletin NMD-27-26 Revision 1 in the airframe log book.

Nomad

SERVICE BULLETIN

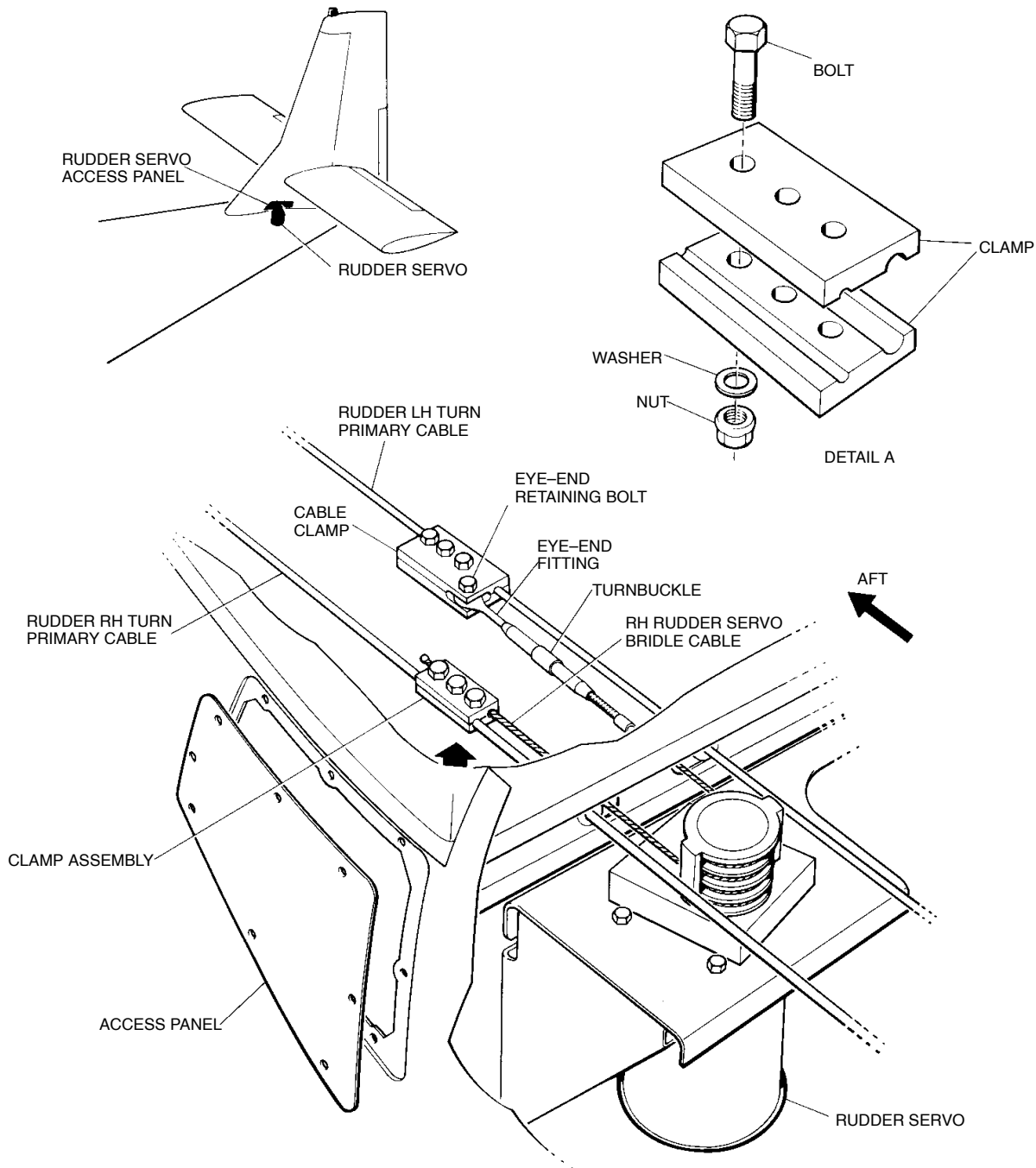

Figure 1 Mod N555-Installation