



GOVERNMENT AIRCRAFT FACTORIES

FISHERMEN'S BEND • 226 LORIMER STREET, PORT MELBOURNE, VIC. • TELEPHONE: 64 0661 PRIVATE BAG NO. 4, POST OFFICE, PORT MELBOURNE, VIC. 3207 •
TELEGRAMS "BEAUF AIR" • TELEX: AA 34397

AVALON AIRFIELD • BEACH ROAD, LARA, VICTORIA, 3212 • TELEPHONE: LARA 82 1202

In Reply Quote S/B NMD-55-9
 Revision 2
7th August, 1981

SUBJECT: NOMAD SERVICE BULLETIN NMD-55-9 - REVISION 2

Ladies and Gentlemen,

Service Bulletin NMD-55-9 - Revision 1 is now issued at Revision 2 and incorporates the following changes.

- (1) All Revision 1 black bars deleted.
- (2) Page 1, Para 1A(1) - Aircraft Affected
Lists of aircraft affected revised and reworded.
- (3) Page 1, Para 1C - Description
"(N22 and N22B) stn 508.31 (N24 and N24A)" added after stn 463.31.
- (4) Page 1, Para 1E - Approval
Approval reworded.
- (5) Page 3, Page 2A
New step (5) and (9) added, original steps re-numbered accordingly.
CAUTION added before step (6).
- (6) Page 3, Para 2B
Step (2) amended at last line.
- (7) Page 5/6, Figure 1
Details A, B and CAUTION added.
- (8) Page 7, Para 2C
New Para 2C added. Original Paras 2C and 2D changed to Paras 2D and 2E respectively.
- (9) Page 7, Para 2D
Note added after Stowage sub-paragraph.
- (10) Page 7
Approval signatures deleted.

(11) Page 8, Para 3A

Labels and Part Numbers added to Kit B.

(12) Page 8, Para 4

Recording instructions revised.

A handwritten signature in cursive script that reads "Bill Henderson".

W. HENDERSON
PRODUCT SUPPORT MANAGER

*Nomad***SERVICE BULLETIN**

SUBJECT: INSTALLATION OF HORIZONTAL STABILISER GUST LOCK (MODIFICATION N386)

1. Planning Information:

A. Effectivity:

(1) Aircraft Affected:

All Nomad N22-Series and N24-Series aircraft which have not had Modification N386 embodied.

Pre-certification implementation of the intent of this service bulletin is recorded in the airframe log book as Mod N386.

(2) Spares Affected:

Nil.

B. Reason

To provide adequate horizontal stabiliser locking in high wind gust conditions.

C. Description

An external control lock is provided which picks up on a permanently installed hook on the horizontal stabiliser and a spigot on the aft fuselage at stn 463.31 (N22 and N22B), stn 508.31 (N24 and N24A). The external control lock is retained in position by a lock pin attached to the fuselage tie down fitting.

D. Compliance

Before 31st July, 1980.

It is recommended that the installation of the horizontal stabiliser hook (Kit A) be incorporated during the removal of the horizontal stabiliser for the incorporation of modification N407B.

E. Approval

The modification detailed herein has been approved pursuant to Air Navigation Regulation 40 and conforms with the type certification requirements.

F. Manpower

Half man day (excluding removal and replacement of horizontal stabiliser).

G. Material - Price and Availability

A kit of parts will be provided on a no charge basis by the manufacturer. The kit will be supplied in two parts:

Kit A - components for the horizontal stabiliser
Kit B - remainder (to be delivered in July 1980).

H. Weight and Balance

Negligible change in aircraft balance.

J. References

I.P.C. - Illustrated Parts Catalogue
M.M. - Maintenance Manual
S.R M. - Structural Repair Manual.

K. Publications Affected

I.P.C.

2. Accomplishment Instructions

A. Aircraft

Kit A

Install Kit A in conjunction with Mod N407B to obviate another removal of horizontal stabiliser.

- (1) Remove the horizontal stabiliser in accordance with the MM 55-20-00.
- (2) Remove the upper surface left hand horizontal stabiliser access panel (I.P.C. 55-10-01 Figure 1 item 12).
- (3) Install the reinforcing channel P/N 1/N-30-190, the gust hook P/N 1/N-30-188 and the reinforcing plate P/N 1/N-30-189 as detailed in Figure 1.
- (4) Balance the horizontal stabiliser as detailed in SRM chapter 55. Correlate balancing with Mod. N407B.

- (5) Refit the horizontal stabiliser in accordance with M.M. 55-20-00 and check the rigging of the stabiliser and associated trim tab control systems (Ref M.M. 27-40-00 and 27-41-00).

Kit B

CAUTION: IF KIT B IS NOT INCORPORATED CONCURRENTLY WITH KIT A THE HORIZONTAL STABILISER CONTROL SYSTEM IS TO BE CHECKED FOR CORRECT RIGGING BEFORE KIT B IS INSTALLED.

- (6) Fit the internal gust lock (Ref MM 27-70-00).
- (7) Fit the spigot assembly P/N 1/N-12-280 on the LH side of the fuselage as detailed in Figure 1. the distance between point A and point B should be 34.25 inches approximately.

NOTE: Point B is located on the bottom LH corner longeron, the spigot assembly attaching rivets, Cherrylock P/N NAS1398MW-5-3 (Alt CR 3223-5-3) replacing existing rivets.

- (8) Attach the external gust lock stay to the gust lock hook on the horizontal stabiliser (Ref sub-para C and Figure 1) and position stay so that spigot is centred on the stay. Mark the point of contact and drill a 8.2 mm (5/16 inch dia) hole in the stay to accommodate the spigot. Ensure correct orientation of the hole with the spigot for the correct engagement of the locking pin P/N 1C/N-88-191 on the gust lock hook.
- (9) Attach labels Part Nos 1/N-00-904 and 1/N-00-905 to the LH side of the rear fuselage (Ref Figure 1) as detailed in M.M. 11-00-00.
- (10) Fix the support bracket for the stowage of the gust lock stay in the rear baggage compartment as shown in Figure 2. Fit the top bracket P/N 1/N-12-282 first and locate the lower bracket using the gust lock stay to obtain the correct distance and alignment.

B. Instruction for Installation of Gust lock

- (1) On parking the aircraft, fit the internal gust lock (Ref MM 27-70-00).
- (2) Engage the external gust lock stay onto the gust lock hook on the horizontal stabiliser and rotate the stay through 90° to engage the retaining pin onto the hook. Test by pulling downwards. Locate stay onto the spigot pin on the side of the fuselage. Lock the stay onto the pin by swinging locking arm onto the rear tiedown and retain by inserting quick release pip pin through locking arm.

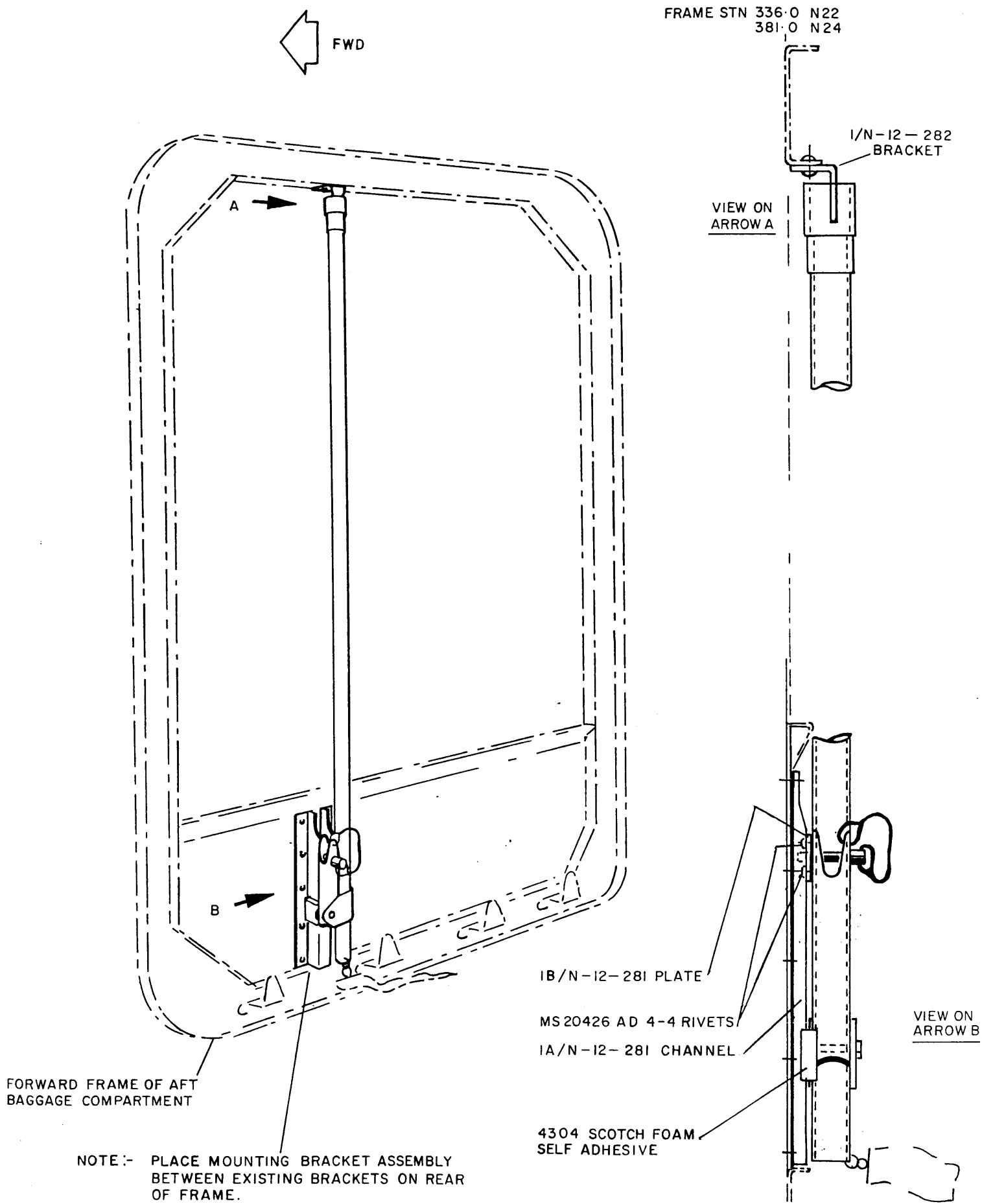

FIGURE 2

FROM
VERTICALLY
BILISER.

LABEL
PT. NO. 1/N-00-905

LABEL
PT. NO. 1/N-00-904

GUST LOCK REMOVAL
REMOVE PIP PIN AND FOLD LOCKING ARM ONTO STAY. WITHDRAW FROM USELAGE SPIGOT ALLOW STAY TO ANG VERTICALLY, ROTATE 90° AND ALLOW TO DISENGAGE.

INSTALLATION REVERSE ORDER.

DETAIL B

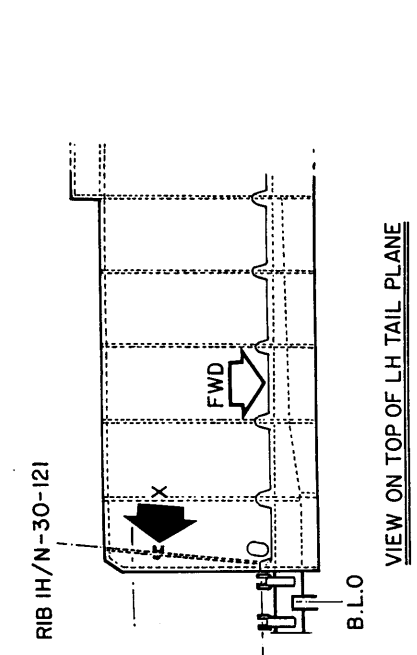
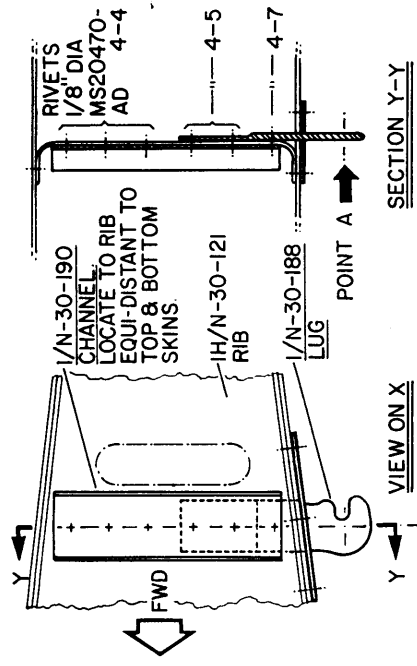

VIEW ON TOP OF LH TAIL PLANE

VIEW ON X

SECTION Y-Y

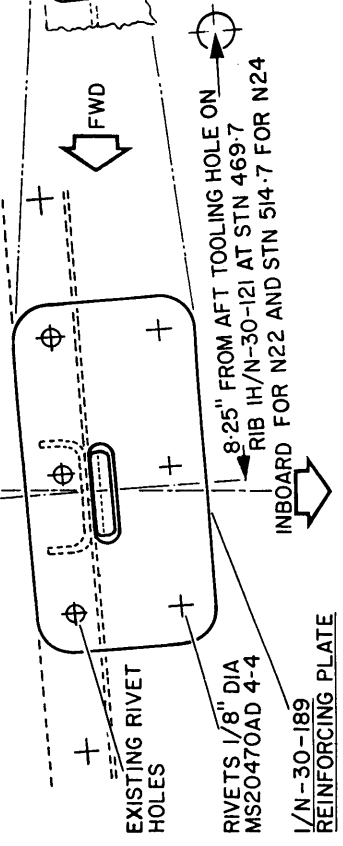

VIEW FROM BELOW ON REINFORCING PLATE

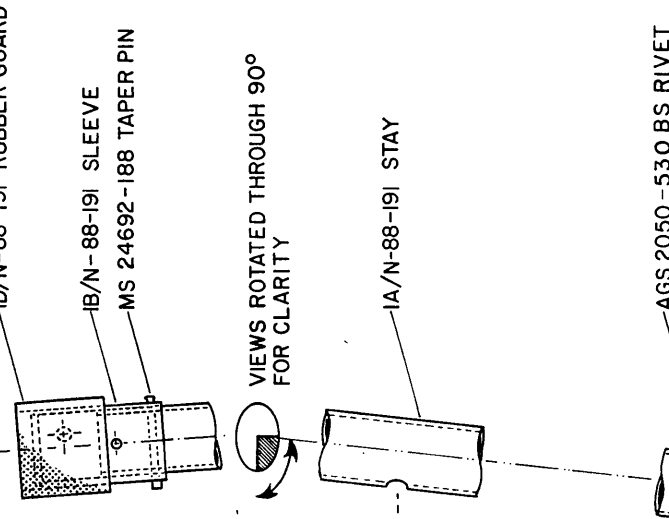
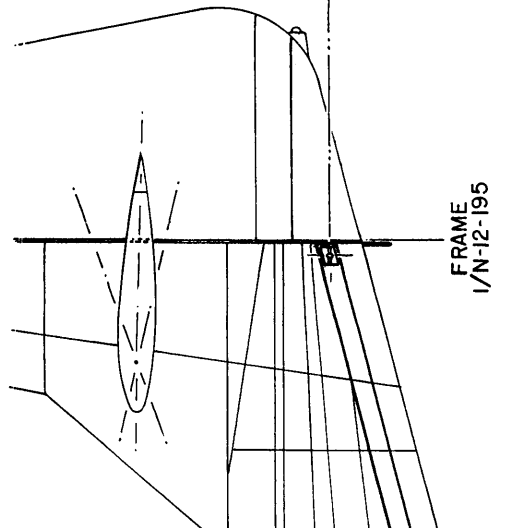

INSIDE OF TAIL SECTION

(3) Engage the rudder wedge gust lock.

C. Instruction for Removal of Gust Lock

(1) Remove the quick release pip pin from the locking arm and swing the locking arm onto the stay. Pull stay away from spigot pin on the side of the fuselage and allow the stay to hang vertically.

CAUTION: WHEN DISENGAGING STAY FROM HORIZONTAL STABILISER, ENSURE STAY IS HELD VERTICALLY TO AVOID DAMAGE TO THE STABILISER.

(2) Rotate the stay through 90 deg. and allow stay to disengage from the gust lock hook on the horizontal stabiliser.

(3) Stow the gust lock in the aircraft (Ref. Para. 2D).

D. Stowage

Mount the gust lock stay on stowage brackets in the rear baggage compartment or rear cabin section as detailed in Figure 2.

NOTE: Stowage of the gust lock as shown in Figure 2 is optional. If an alternative stowage is used, operators should ensure that the gust lock is safely and securely stowed.

E. Modification Action

This service bulletin incorporates the intent of modification N386.

3. Material Information

A. Parts Required per Aircraft

<u>Part Number</u>	<u>Quantity</u>	<u>Nomenclature</u>
<u>Kit A</u>		
1/N-30-188	1	Hook gust lock
2/N-04-153	Alt've	Hook gust lock
1/N-30-190	1	Channel
1B/N-04-153	Alt've	Channel
1/N-30-189	1	Reinforcing plate

<u>Part Number</u>	<u>Quantity</u>	<u>Nomenclature</u>
<u>Kit B</u>		
1/N-88-191	1	Gust lock stay assy
1/N-12-281	1	Mounting bracket assy
1/N-12-282	1	Bracket
1/N-12-280	1	Spigot assy
5/N-04-153	Alt've	Spigot assy
1/N-00-904	1	Label
1/N-00-905	1	Label

B. Part Required to Modify Spares

Nil.

C. Removed Parts

Nil.

D. Special Tools and Equipment Required

Nil.

4. Record compliance with service bulletin NMD-55-9 Rev. 2 in the airframe log book.