

PO Box 881, Morwell, Victoria 3840, Australia  
Ph + 61 (0) 3 5172 1200  
Fax + 61 (0) 3 5172 1201  
www.gippsaero.com

# Service Bulletin

## Subject:

Installation of parachute options/modifications.

## Applicability:

GA8 and GA8-TC 320 all serial numbers.

## Amendments:

- Issue 2: Internal Grab Handle, GA8-526017-11, added, inclusive of details.
- Issue 3: Numbering sequence revised & references corrected.
- Issue 4: Step option removed.
- Issue 5: New Internal Grab Handle Assembly added.
- Issue 6: Door holding parts added.
- Issue 7: Added LH flap reinforcement. Updated documentation section. Parts updated to appear in kits. Ref: GAE11#1304
- Issue 8: Item 18 part number updated. Ref: GAE11#2413.

## Background:

Owners who conduct parachute operations have requested several modifications and optional enhancements to support their operations. Each of these options can be installed independently at the owner's discretion. If the static line anchor is installed the wind deflector must be strengthened by the addition of a steel wind deflector foot. The aim of the LH flap reinforcement is to minimise damage to the trailing edge caused by parachuting operations.

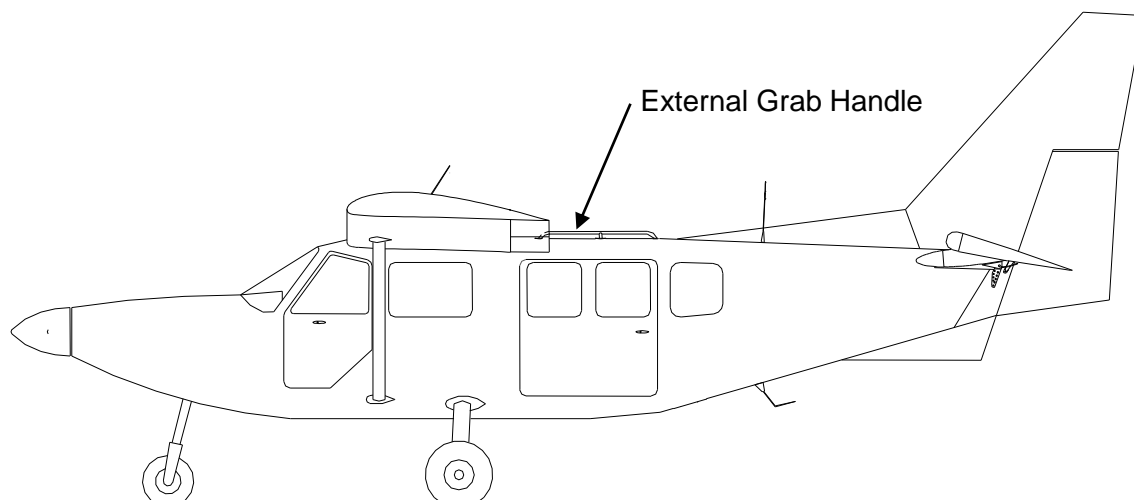

**Figure 1: General Arrangement**

## Compliance:

These modifications may be installed at the owner's discretion.

## Weight and Balance:

External Grab Handle:	0.8 kg (1.7 lb) at an arm of 2985 mm (117.5 in) aft of datum.
Static Line Anchor:	The change in weight and balance is negligible.
Internal Grab Handle:	0.55 kg (1.2 lb) at an arm of 2962 mm (116.6 in) aft of datum.
Door Stop Installation:	The installation does not affect the weight and balance of the aircraft.
LH flap skin reinforcement	1kg (2.2lbs) at an arm of 2484mm (97.8 inches) aft of datum.

## Approval:

The technical aspects of this modification has been approved pursuant to Regulation 21.095 of CASR(1998).

## Parts:

Item	Part Number	Description	Qty
<b>Grab Handles (Kit SB-GA8-2005-31-1)</b>			
1	GA8-526017-13	Internal Grab Handle	1
2	GA8-526013-17	Parachute Handle	1
3	GA8-526023-73	Plate Packer Handle	1
4	AN525-832R8	Structural Screw	15
5	AN960-8	Washer	15
6	MS21042-08	Reduced Hex Nut	15
7	MS20426AD3-3	C/S Rivet	1
8	MS20426AD3-3.5	C/S Rivet	1
9	MS20426AD4-3	C/S Rivet	3
10	MS20426AD4-4.5	C/S Rivet	2
11	MS21042-04	Reduced Hex Nut	2
<b>Static Line Anchor (Kit SB-GA8-2005-31-2)</b>			
12	GA-000364-13	Static Line Assy	1
13	GA-000370-21	Parachute Static Line Safety Lock	2
14	GA-000371-11	Deflector Foot Mount	1
15	A10K80 (GippsAero order code: 412G00009)	Rivnut	4
16	SSD42SSBS (GippsAero order code: 404G00011)	Pop Rivet	2
17	AN525-10R6	Structural Screw	4

<b>Door Holding Device (Kit SB-GA8-2005-31-3)</b>			
18	GA8-526016-021	Cargo Door Stop Plate Assy	1
19	GA8-526016-17	Cargo Door Stop Assembly	1
<b>LH Flap skin reinforcement (Kit SB-GA8-2005-31-4)</b>			
1	GA8-576021-101	LH Flap skin reinforcement	1
2	TLPD321BS (GippsAero order code: 404G00006)	Pop rivet	85

### **Parts Availability:**

New parts can be obtained directly from GippsAero.

Tel.: +61 03 5172 1208

Fax.: +61 03 5172 1237

Email: [aircraft.parts@mahindraaerospace.com](mailto:aircraft.parts@mahindraaerospace.com)

### **Labour:**

Grab Handles: 1 hour labour should be allowed for the installation of the grab handles.

Static Line Anchor: 0.5 hours should be allowed for installation of the consequential modifications associated with the static line anchor.

Door Stop Installation: 0.5 hours should be allowed for the installation of the door stop installation.

LH Flap Skin Reinforcement: 4 hours should be allowed for the installation of the LH flap skin reinforcement.

## Instructions:

The instructions in this service bulletin assume an appropriately licensed technician is performing the work with typical sheet metal working tools.

Instruction 1 is intended to be read in conjunction with the relevant drawing.

### 1. External Grab Handle

The parachute grab handle is to be installed as follows:

- 1.1. Remove the interior panels in the vicinity of the door to gain access to the structure, see Service Manual.
- 1.2. Locate and remove the appropriate rivets in the roof structure, figure 2 and 2a, 2b, 2c.



Figure 2: Location of the Holes on the Roof.

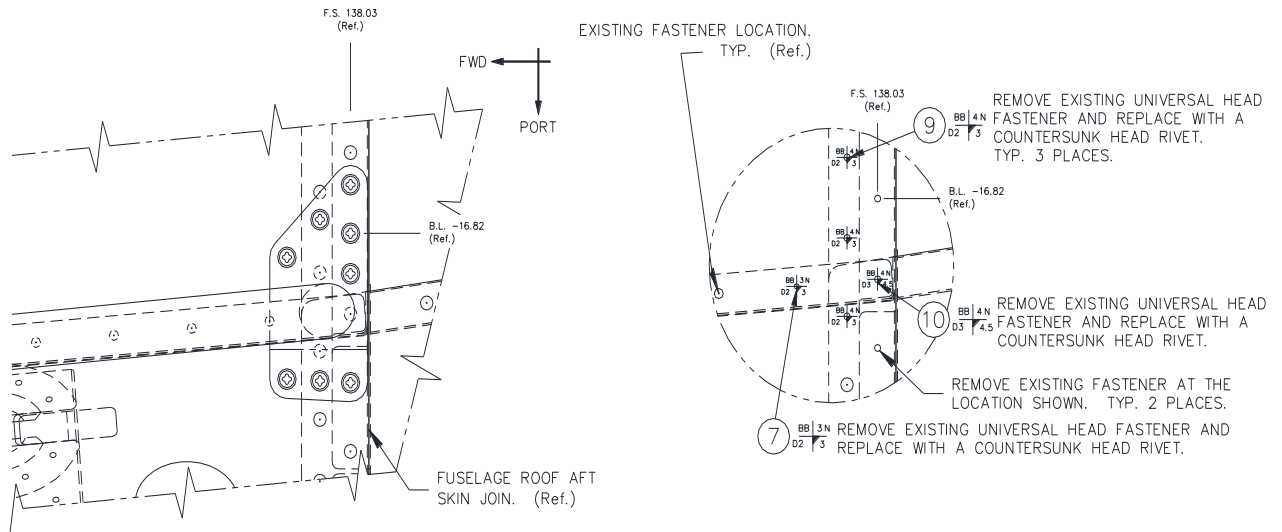

Figure 2a

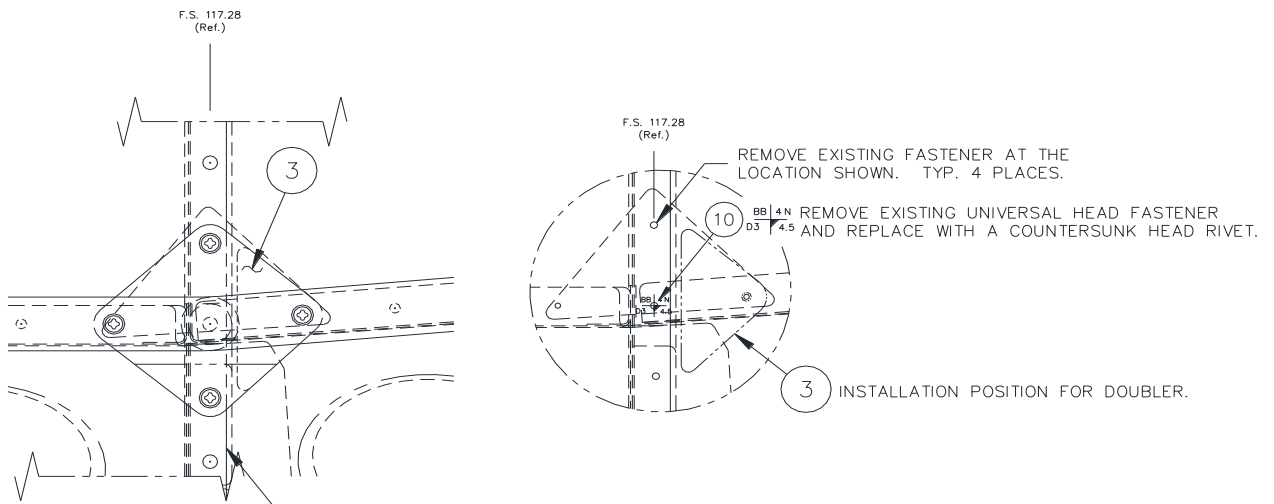

Figure 2b

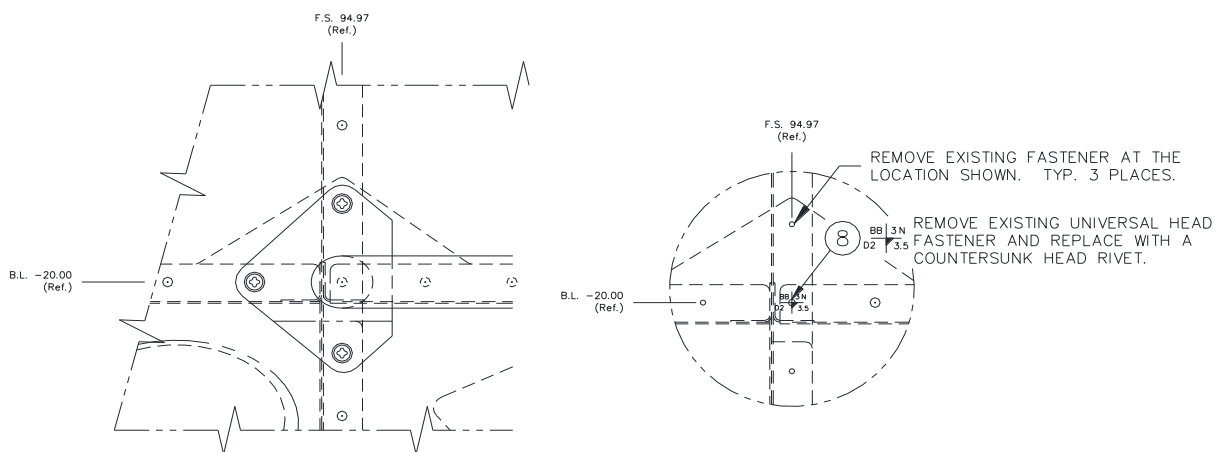

Figure 2c

- 1.3. As appropriate reinstall countersunk rivets as per figures above (Items 7, 8, 9 and 10).
- 1.4. Locate the parachute handle over the remaining holes and drill through the handle  $\text{\O}0.169$ . Secure handle by placing a bolt in the first hole in each attachment point to maintain alignment.
- 1.5. Deburr the holes and install the handle using the hardware specified (items 4, 5 and 6). Ensure item 3, doubler is fitted under the middle attaching point (figure 2b).
- 1.6. Reinstall the panels and install the door handle as per figure 3.

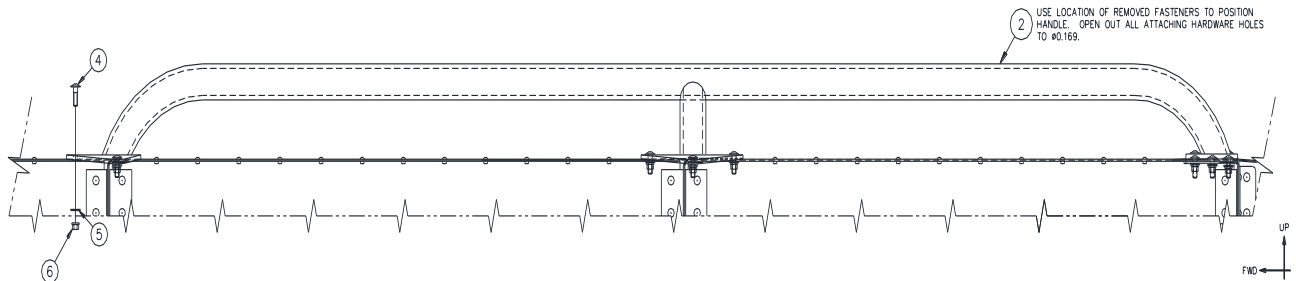

Figure 3

## 2. Static Line Anchor

The static line anchor may be installed or removed by the pilot. However it is necessary to install 2 rivnuts in the floor for the parachute static line safety lock, 2 rivnuts for the wind deflector foot and the wind deflector must be modified by the installation of the foot.

- 2.1. Position the Static Line Anchor into the seat fittings. See Flight Manual supplement C01-04-58 for the correct locations.
- 2.2. Position the Static Line Lock, item 16 such that the upright leg is between the static line foot and the retaining spring. See Figure 4.

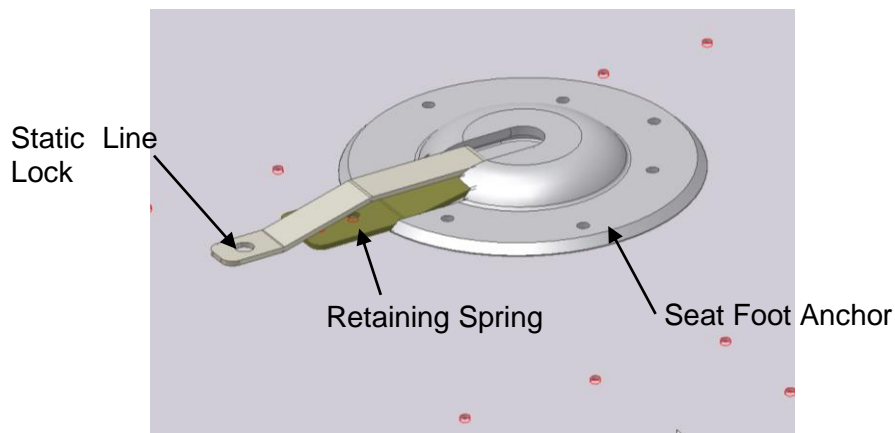
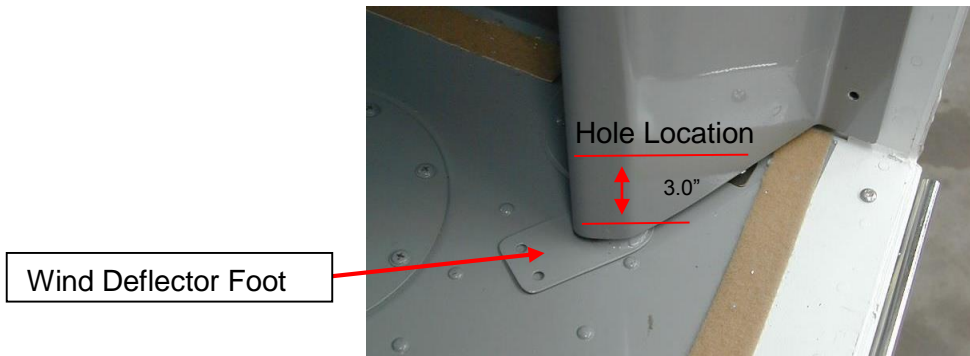

Figure 4 Static Line Lock

- 2.3. Mark the centre of the hole in the safety lock onto the floor and drill a  $\text{\O}0.25$ " hole in the floor. Notch the hole using a rattail file or similar to provide a keyway for the rivnut.
- 2.4. Using the correct rivnut installation tool install Item 8 in the floor ensuring alignment of the rivnut key lock with the key way.
- 2.5. Repeat steps 2.2 to 3.4 for the other end of the static line anchor.
- 2.6. Position the wind deflector foot, Item 7, in the wind deflector and install the wind deflector in the aircraft. Position the foot flat on the floor, clear of all rivet heads. See Figure 5.



**Figure 5: Wind Deflector Foot Location**

- 2.7. Measure up from the floor 1.5" and 3" along the wind deflector and drill a  $\text{Ø}0.125$ " hole at each height such that the drill passes through the deflector and the footspring where the steel foot is hard against the deflector.
- 2.8. Apply a liberal quantity of Duralac or similar joining compound to the faying surface and rivet the foot to the deflector using item 9.
- 2.9. With the deflector in place mark the location of the holes in the foot on the floor. Remove the deflector and drill the floor  $\text{Ø}0.25$ . Notch the hole using a rattail file or similar to provide a keyway for the rivnut. Using the correct tool install item 8 ensuring alignment of the rivnut key lock with the key way.

### 3. Internal Grab Handle

The internal grab handle is installed as follows:

- 3.1. Depress the retaining springs and slide handle into place as shown in figure 6a and 6b.

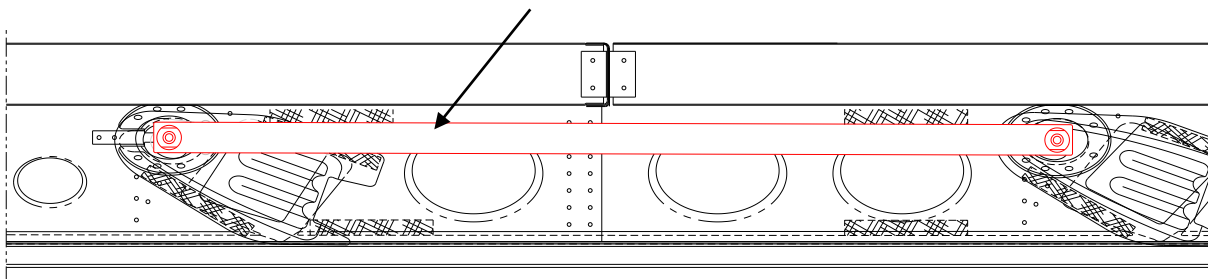

**Figure 6a: Internal Grab Handle Installation**



**Figure 6b: Internal Grab handle installation**

#### 4. Door Stop Installation

The door stop installation is installed as follows:

- 4.1. Remove the existing MS24694-S52 screw and install it with, item 19, cargo door stop assembly (Figure 7).

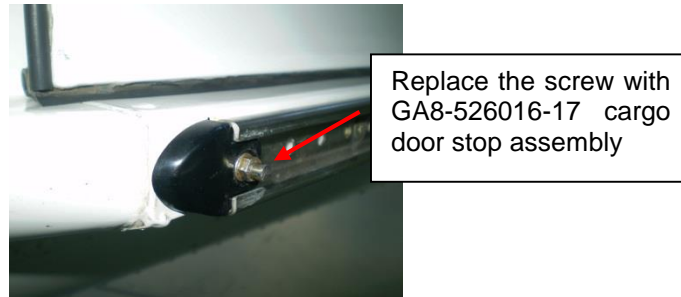

Figure 7: Fwd Door Stop Installation

- 4.2. Remove lower door guide bracket assembly and reassemble door guide bracket by installing, Item 18, Cargo Door Stop Plate Assy as per Figure 8.



Figure 8: Fwd Door Stop Installation

- 4.3. The door stop plate is installed adjacent to the door guide plate.
- 4.4. Ensure the stop plate engages the stop assembly.

#### 5. Flap Skin Reinforcement

The LH flap skin reinforcement is installed as follows:

- 5.1. Remove the LH flap in accordance with Section 27-50-20 of the GA8 Service Manual.
- 5.2. Place GA8-576021-101 LH Flap Skin Reinforcement over the inboard flap skin, noting that the lower surface of the flap skin has the cut-out for the drop arm. Ensure that the skin is kept fairly tight, and contoured along the existing flap skin so that there will be no bulging, or rippling. Line up the skin to ensure an edge distance of 0.25"-0.30" from the edge of the skin reinforcement to the centre of the existing rivets installed along the main spar on both upper and lower surfaces. Note: Holes on trailing edge are drainage holes.
- 5.3. Using a 2.85mm drill bit, drill holes in the LH skin reinforcement and flap skin which are to be in line with the existing rivets in the flap spar. Drill holes between existing rivets in the spar at gaps closest to corners and then rivet spacing is to be in between second gap along the spar. Pin in place as holes are drilled.
- 5.4. Back-drill the punched holes in the lower surface of the LH flap reinforcement skin into the flap using a 2.85mm drill bit.
- 5.5. Install TLPD321BS rivets to fasten the LH reinforcement skin to the lower side.
- 5.6. Repeat Step 5.4, 5.3 then 5.5 for the upper surface of the flap skin.



- 5.7. Use Sikaflex 221, or similar, sealant to seal around the perimeter of the LH flap reinforcement skin. Touch up paint as required.
- 5.8. Reinstall the flap in accordance with Section 27-50-25 and 27-50-15 (for Rigging) of the GA8 Service Manual.
- 5.9. Touch up paint as required.



**Figure 7 : LH flap skin reinforcement**

**Documentation:**

Ensure Flight Supplement C01-01-01 Supplement 1: Inflight Rear Door Open Operations and C01-01-01 Supplement 2: Parachute Operations are inserted into aircraft flight manual.

Insert supplement C01-04-58 in the aircraft flight manual if static line anchor is installed.

Update aircraft log book to reflect incorporation of the relevant aspects of this Service Bulletin.

**Compliance Notice:**

Complete the Document Compliance Notice and return to GippsAero by fax or mail.

## DOCUMENT COMPLIANCE NOTICE



A Mahindra Aerospace Company

Document:

**SB-GA8-2005-31**

**Issue 8**

Aircraft Serial Number: GA8-\_\_\_\_\_

The following parts of Service Bulletin SB-GA8-2005-31 Issue 8 have been incorporated in the above aircraft (Tick as appropriate):

- SB-GA8-2005-31: External Grab Handle
- SB-GA8-2005-31: Static Line Anchor
- SB-GA8-2005-31: Internal Grab Handle
- SB-GA8-2005-31: Door Stop Installation
- SB-GA8-2005-31: LH Flap Skin Reinforcement

Date of Incorporation: \_\_\_\_\_

\_\_\_\_\_  
Signed

Print Name: \_\_\_\_\_

Please post, email or fax this compliance notice to:

GippsAero

Attn: Technical Publications

Email: [aircraft.techpubs@mahindraaerospace.com](mailto:aircraft.techpubs@mahindraaerospace.com)

P.O. Box 881

Morwell Victoria 3840

Australia

Fax: +61 03 5172 1201