

# Service Bulletin

---

**Subject:**

Horizontal Stabiliser Aft Pivot Modification

**Applicability:**

All GA8 serial numbers GA8-00-004 through GA8-04-060.

**Amendments:**

Nil (initial issue).

**Background:**

To reduce horizontal stabiliser aft pivot bush wear and loosening, a larger bush has been developed. This Service Bulletin documents the installation procedure for the larger bush and replacement of rivets in the horizontal stabiliser pivot bracket with bolts to facilitate ease of reassembly and future maintenance.

**Compliance:**

For applicable aircraft this optional Service Bulletin may be incorporated at the owner's discretion.

**Weight and Balance:**

Negligible effect on weight and balance.

**Approval:**

This modification has been approved pursuant to Regulation 35 of CAR1988.

## Parts:

Item	Part Number	Description	Qty
1	GA8-551021-97	BUSH	2
2	AN356-524	PAL NUT	2
3	AN960-10 (NAS1149F0363P)	WASHER	18
4	AN960-10L (NAS1149F0332P)	WASHER (THIN)	18
5	AN960-516	WASHER	2
6	MS20142-3	NUT	18
7	MS21042-5	NUT	2
8	NAS6603-7	BOLT	18
9	NAS6605-20	BOLT	2

## Parts Availability:

New parts can be obtained directly from Gippsland Aeronautics.

Tel.: +61 03 5172 1200

Fax.: +61 03 5172 1201

Email: support@gippsaero.com

## Instructions:

### 1. Installation

1. Support the horizontal stabiliser over the aft fuselage, removing fairings as necessary.
2. Remove the horizontal stabiliser aft pivot bolts.
3. Drill out the attachment rivets of the horizontal stabiliser pivot brackets, P/N's GA8-538021-233 and GA8-538021-234, and with the brackets still fastened to the aft fuselage skin by the 4 bolts, open out the holes to  $0.189" \pm 0.001"$  ( $4.8 \pm 0.025$  mm).
4. Remove the 4 bolts in each of the pivot brackets and remove the brackets from the aft fuselage.
5. Line bore and ream the bush hole in each horizontal stabiliser pivot bracket to diameter  $0.625" \begin{matrix} +0.0005" \\ -0.0000" \end{matrix}$  ( $15.875 \begin{matrix} +0.0127 \\ -0.0000 \end{matrix}$  mm).

### **NOTE:**

*Horizontal stabiliser bracket bush hole must be machined accurately or extensive repairs will be required.*

6. Drill a lubrication hole with diameter  $0.078" \pm 0.005"$  ( $1.984 \pm 0.127$  mm) in the pivot brackets as per figure 4, and chamfer the outer edge of the hole  $0.05" \pm 0.005"$  ( $1.27 \pm 0.127$  mm) with a  $45^\circ$  countersink.
7. Install the brackets using items 3, 4, 6, and 8 as per figures 1 and 2. Pack bolt threads with thin washer (item 4) under the bolt head, and a washer (item 3) under the nut (item 6).
8. Attach the stabiliser aft pivot channel mount to the fuselage pivot bracket using items 1, 2, 5, 7 and 9 as per figures 2 and 3.
9. Lubricate the bushes using general-purpose grease through the lubrication holes in the brackets.

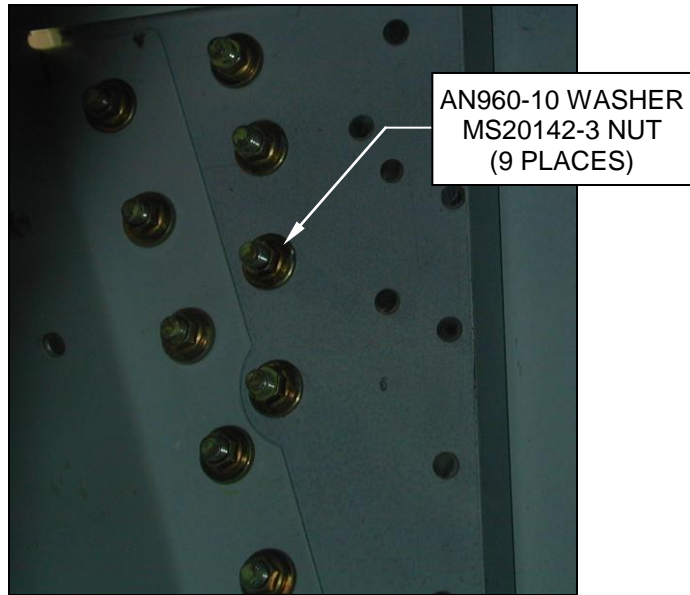

**Figure 1: Finished modified pivot installation (looking from inside the aft fuselage).**

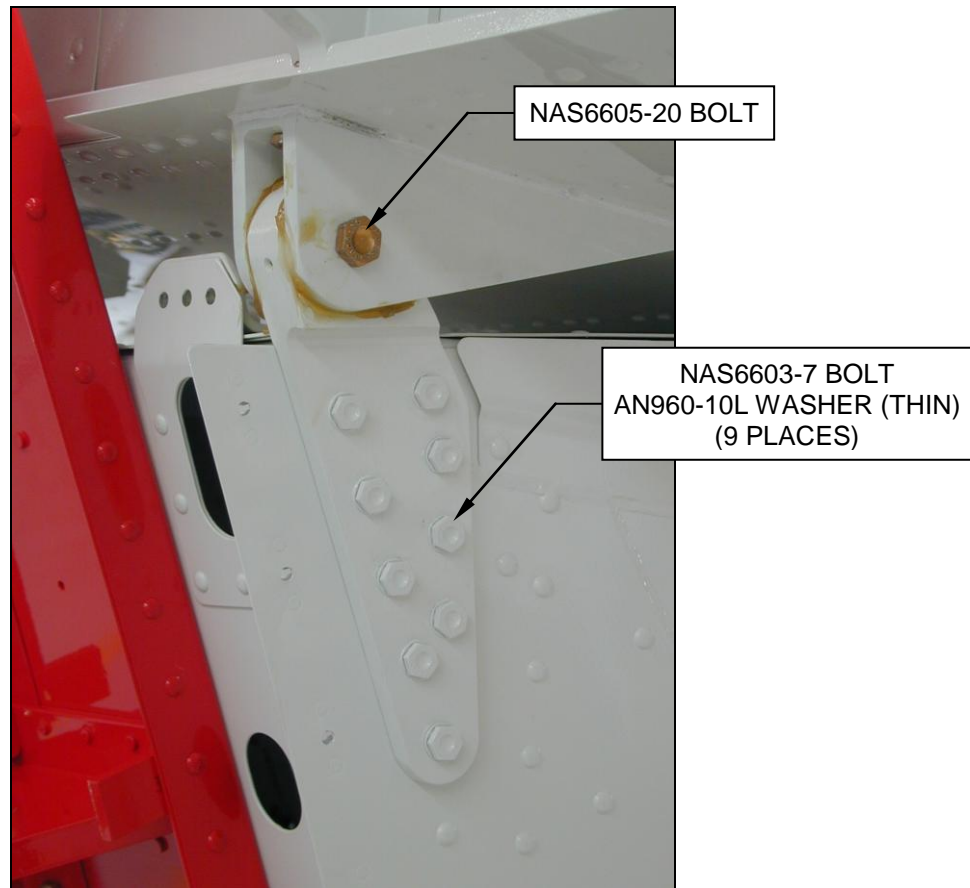

**Figure 2: Finished modified pivot installation.**

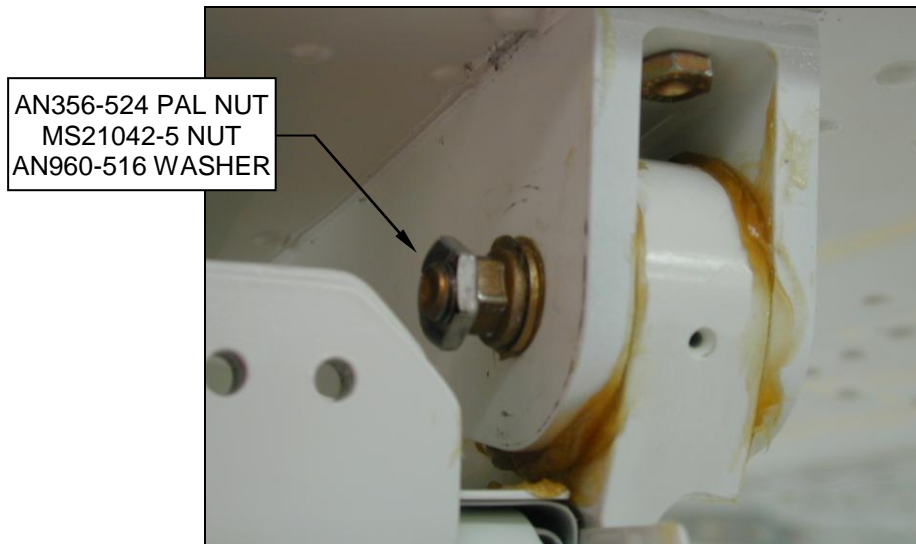

**Figure 3: Finished modified pivot installation.**

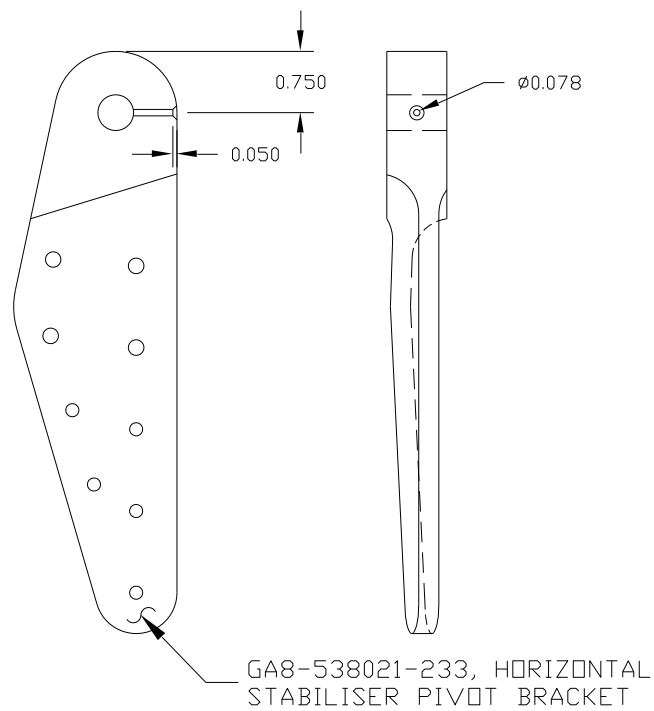

**Figure 4: Lubrication hole geometry.**

**Documentation:**

Update aircraft log book to reflect incorporation of this Service Bulletin.

**Compliance Notice:**

Complete the Document Compliance Notice and return to Gippsland Aeronautics by fax or mail.

## DOCUMENT COMPLIANCE NOTICE



Document: Service Bulletin SB-GA8-2005-21

Aircraft Serial Number: GA8-\_\_\_\_\_

Service Bulletin SB-GA8-2005-21 has been incorporated for the above aircraft.

\_\_\_\_\_  
Signed

Print Name \_\_\_\_\_

Please post or fax this compliance notice to:

Gippsland Aeronautics  
Attn: Technical Services  
P.O. Box 881  
Morwell Victoria 3840  
Australia  
Fax.: +61 03 5172 1201